



Model
UHH

Universal Handheld Test Instrument

Versatile Base Can Combine with Multiple Probes and Modules



TEST EQUIPMENT

HVAC Balancing Instruments



Scan here
to watch
product video

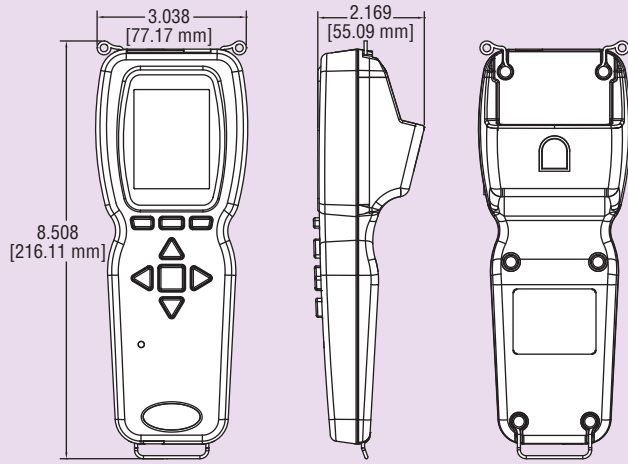

The Model UHH Universal Handheld Test Instrument is a highly versatile instrument that offers the utmost flexibility and ease of user operation by having the capacity to work with a variety of Dwyer Instruments, Inc. compatible sensing modules and probes. Additional wired and wireless probes or modules are instantly recognized by the UHH without any user reprogramming or alteration, allowing seamless sensor addition, upgrade or replacement. The Universal Handheld offers a slew of features that enable a technician to quickly set up and intuitively navigate through their daily activities. Data is stored via the internal memory or separate SD card in various auto or manual logging operations. Logged files can be quickly transferred to a device through a USB cable or by a portable SD card. The display can operate in standard numerical meter mode, gage mode with analog needle, gage mode with additional pass/fail operation zones, and strip chart mode which enables a simplified visual tracking of the process. The four directional buttons, combined with the three soft key buttons aligning to corresponding screen functions, allow for quick navigation through the four main operation menus. The rugged plastic case with protective thermo-plastic over-mold, along with the dust-shielding rubber caps, permit the unit to handle abuse and properly withstand dusty environments. The base UHH includes an integral molded compartment that securely holds wireless modules. The storage compartment offers convenient transportation of a module with the base instrument during testing. A flexible hand strap included with every UHH provides means for the base handheld to be safely connected to a belt, pipe, ladder or similar structure freeing the user's hands to focus on the sampling test. A 6-pin connector enables one wired probe at a time to be plugged in to the base instrument without worry of becoming disconnected during sampling. The rechargeable battery via the included USB cable provides long term operation to last through several days work. At just under 10 oz, the compact UHH base is lightweight. Included with the UHH is a soft carrying case which secures the provided accessories and added test probe.

SPECIFICATIONS

Languages: English, German, Italian, Portuguese, Spanish.

Display: OLED, color 240 x 320.

Temperature Limits: 5 to 125°F (-15 to 51°C);

Note: When using wireless function: 20 to 125°F (-6 to 51°C).

Battery Charging Limits: 32 to 113°F (0 to 45°C).

Resolution: 1 FPM, 0.1 MPS, 0.1 CFM & M³/HR; 0.1°F & °C; RH 0.1%.

Units Air Velocity: FPM, MPH, KN, M/H, M/S K/H, FPS.

Units Flow: CFM, M³/HR, M³/S, GPM, GPH, GPD, LPS, LPM, LPH.

Units Temperature: °F, °C.

Housing: Thermoplastic elastomer over polycarbonate.

Power Requirements: 3 V BR1225 lithium metal battery, installed functional, non-replaceable and 3.7 V lithium ion battery, installed functional, non-replaceable.

Note: Intended to be operated with power cables less than 3 m in length).

Maximum Wireless Distance: 50' (15 m).

Weight: 10 oz (283 g).

Agency Approval: CE (not while charging), FCC compliant.

UHH FEATURES

- UHH base quickly recognizes various wired or wireless probes and modules - eliminates need to have many test instruments on hand, reducing time to complete job.
- Easy navigation through 4 menus via directional arrow buttons and 3 soft keys.
- Large color display can operate in 4 process reading modes. ②
- Inherent rubber overmold housing combed with protective caps enable units to withstand abuse in dusty environments.
- Integral strap clips allow units to be secured during testing with included hand strap to a belt, pipe, ladder, etc. providing hands free operation.
- LED status light transmits visual feedback when unit's long lasting lithium battery is being charged by the USB connection. Also indicates when a data point is stored.
- Manual or automatic data logging modes include several adjustable parameters that enable the user to obtain readings in a multitude of potential test scenarios.
- Internal memory or expanded memory with portable SD card provides ample data logging capacity. Data is transferable via the USB connection or by removing the SD card and inserting into compatible SD card device.
- Flexible ordering allows customization to fulfill personal needs by ordering UHH and additional probes a-la-carte or by pre-set test kits. ③

UHH INCLUDED ACCESSORIES

UHH-STRAP: Hand strap.

UHH-ICHRG: Dual USB wall or auto charger with international adapters.

UHH-CBL: 3.2 ft (1 m) USB cable.

UHH-C1: Soft carrying case.



UHH-C1
Soft Carrying Case



UHH-ICHRG
Dual USB Charger



UHH-STRAP
Hand Strap

① Available sensors: See pages 426-428
 ② Views of each mode: See page 425 (Series UHH)
 ③ Pre-set test kits: See page 423 (Series AQT1)



User Selectable Display Operation

Meter Mode

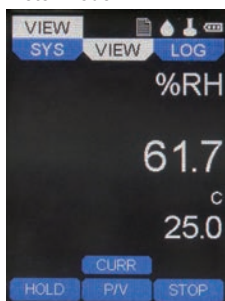

Standard numerical values. Peak/Valley, Average and (depending on sensor) Total values easily selectable with soft key.

Gage Mode

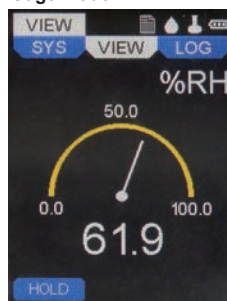

Analog Gage displays the pointers reading location on the full-scale dial plus the actual numerical value.

Range Mode



Similar to Gage mode with additional programmable green band for quick visual of test pass or fail status.

Strip Chart Mode

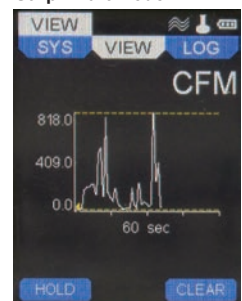

Strip chart shows the process over selectable period of time. The charts y-axis also can be adjusted.

Model	Description
UHH	Base model with hand strap, charger/cable in soft carrying case
AP1	Thermo anemometer air velocity & temperature probe with coiled cable
RP1	Thermo hygrometer humidity & temperature probe with coiled cable
AP2	Wireless thermo-anemometer air velocity & temperature probe
RP2	Wireless thermo-hygrometer humidity & temperature probe
VP1	100 mm vane thermo-anemometer air velocity, temperature and humidity probe with coiled cable
VP2	Wireless 100 mm vane thermo-anemometer air velocity, temperature and humidity probe

Note: For available sensors, see page reference ● below.

ACCESSORIES

- UHH-STRAP, UHH hand strap
- UHH-ICHRG, UHH dual USB charger with international adapters (1.0 A) (Not CE approved)
- UHH-CBL, USB cable
- UHH-C1, Soft carrying case
- UHH-SD, 2 GB SD card
- KF-CC-304, Dual USB CHARGER with North American adapter (1.5 A)
- UHH-C2, Heavy duty hard case with pre-cut foam inserts for additional sensors

● Available sensors: See pages 426-428