

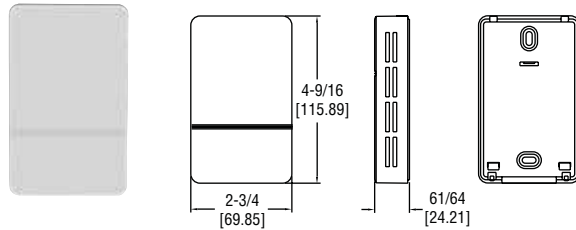

Series RHL Temperature/Humidity Transmitter

Specifications - Installation and Operating Instructions

Wall Mount



Duct Mount

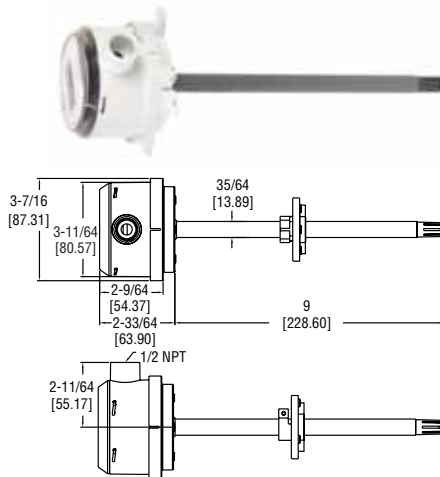

OSA (Outside Air)

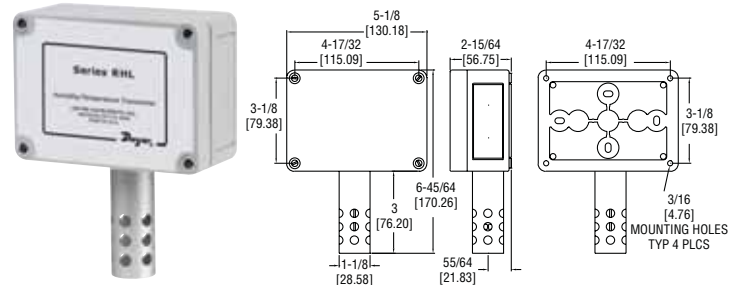

The ultra-fast Series RHL Transmitter provides a stable, repeatable, and accurate means of measuring humidity only or both temperature and humidity in the harshest of environments. The polymer capacitance sensor is not affected by condensation, fog, high humidity or contaminants. Sophisticated integrated circuits provide a high level, fully conditioned, and temperature compensated 4-20 mA or 0-10V output signal. Dual output humidity/temperature transmitters are also available with an optional 2-line alpha numeric LCD. (On duct mount only)

INSTALLATION

Warning: Disconnect power supply before installation to prevent electrical shock and equipment damage.

Make sure all connections are in accordance with the job wiring diagram and in accordance with national and local electrical codes. Use copper conductors only.

Caution: Use electrostatic discharge precautions (e.g., use of wrist straps) during installation and wiring to prevent equipment damage.

Avoid locations where severe shock or vibration, excessive moisture or corrosive fumes are present. NEMA Type 4X (IP65) housings are intended for outdoor use primarily to provide a degree of protection against wind-blown dust, rain, and hose-directed water.

Do not exceed ratings of this device, permanent damage not covered by warranty may result. The 4-20 mA models are not designed for AC voltage operation.

SPECIFICATIONS

Relative Humidity Range: 0 to 100% RH.

Temperature Range: -40 to 140°F (-40 to 60°C).

Accuracy: ±3% 10 - 90% RH; ±0.9°F @ 72°F (±0.3°C @ 25°C).

Hysteresis: ±1%.

Repeatability: ±0.1% typical.

Temperature Limits: -40 to 140°F (-40 to 60°C).

Storage Temperature: -40 to 176°F (-40 to 80°C).

Compensated Temperature Range: -4 to 140°F (-20 to 60°C).

4-20 mA Loop Powered Models:

Power Requirements: 10-35 VDC.

Output Signal: 4-20 mA, 2 channels for humidity/temperature models (loop powered on RH).

0-10V Output Models:

Power Requirements: 15-35 VDC or 15-29 VAC.

Output Signal: 0-10V @ 5 mA max. 2 channels for humidity/temperature models.

Response Time: 15 seconds.

Electrical Connections: Screw terminal block.

Conduit Connection: Duct mount: 1/2" NPS; OSA: 1/2" (22.3 mm).

Drift: <1% RH/year.

RH Sensor: Capacitance polymer.

Temperature Sensor: Solid state band gap.

Housing Material: Wall Mount: ABS; Duct Mount: PBT; OSA: Polycarbonate.

Enclosure Rating: NEMA 4X (IP65) for OSA mount only.

Display: Optional 2-line alpha numeric, 8 characters/line. (On duct mount only)

Display Resolution: RH: 0.1%; 0.1°F (0.1°C).

Weight: Wall Mount: 0.5 lb (0.25 kg); Duct Mount: 0.6 lb (0.3 kg); OSA: 1 lb (0.45 kg).

Agency Approvals: CE.

Wall Mount

The wall mount models must be mounted as described below:

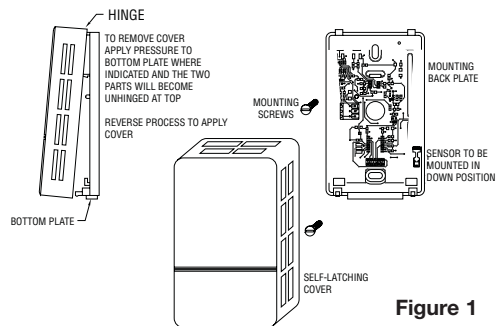

Figure 1

1. Remove top of base. Push button on bottom of base and lift off cover. See Figure 1.
2. Select the mounting location, locate away from diffusers, lights, or any external influences.
3. Mount transmitter on a vertical surface to a standard electrical box using the two #6 M2C type screws provided.
4. Pull wires through sub base hole and make necessary connections.
5. Replace top of base.

Duct Mount

The transmitter should be mounted away from fans, corners, heating and cooling coils, and other equipment that will effect the measurement of the relative humidity. It should also be mounted in a location that receives adequate air flow for proper operation.

1. Drill a 1" diameter hole into the duct at the desired location.
2. Center the adjustable mounting ring over the 1" hole. Tap the ring to mark the position of the three #8 sheet metal screws.
3. Remove the mounting ring and drill or punch in the marked hole locations.
4. Install the ring on the duct.
5. Insert the transmitter probe through the mounting ring until the sensor is in the center of the duct. Tighten the set screw on the side of the mounting ring.
6. Remove top screw cover to access wiring terminals.

OSA (Outside Air)

The transmitter should be mounted under an eave, shield, or in an area that is out of the elements or direct sunlight. The transmitter should be mounted with the sensor pointing down to prevent water collection in the sensor cavity.

1. Remove the cover plugs from the face of the unit and the top cover.
2. Position the transmitter where it is to be mounted and mark the mounting holes in each corner of the housing.
3. Drill or punch out marked locations.
4. Place the transmitter box over mounting holes on wall and align. Install wall mount screws (not provided) in mounting holes.
5. Proceed with wiring according to Figure 2. A liquid tight cable connection is included with the unit. Fits .100 - .260 dia. cable.
6. Replace cover and cover plugs on the face of the unit.

WIRING

Use maximum 18 AWG wire for wiring terminals. Refer to Figures 1 and 2 for wiring information.

4-20 mA Output Models

4-20 mA output units may be powered with a 10-35 VDC supply. The following describes the proper wiring of these transmitters with mA output.

The Model RHL transmitter is designed as a two-wire 4-20 mA device with two channels. The channels are common on the positive side of the current loops.

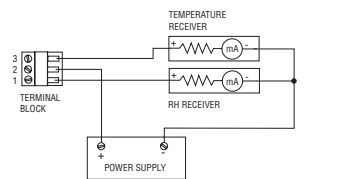

Figure 2

Sensor excitation power is derived from the relative humidity channel, so power must always be applied to that channel. If the temperature channel is not equipped or used, it can be left disconnected. The basic two-wire connection is shown in Figure 2.

0-10V Output Models

The 0-10V output models may be powered with 15-35 VDC or 15-29 VAC. Note polarity when using DC power. The channels are common on the negative side. For units with RH and temperature outputs, either or both outputs may be used. The maximum load is 5 mA (2 k ohms) for each output. Wire as shown in Figure 3.

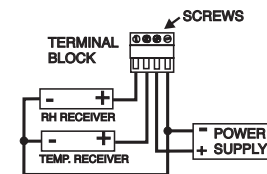

Figure 3

DISPLAY

The temperature indicated on the display, if equipped with the LCD option, is field selectable via a jumper located on the circuit board. Position the jumper for °F or °C according to Figure 4.



Figure 4

CHECKOUT

1. Verify that the unit is mounted in the correct position.
2. **4-20 mA Models:**

Verify appropriate supply voltage. The transmitter requires a minimum of 10 and a maximum of 35 VDC at its connection for proper operation. Choose a power supply with a voltage and current rating which meets this requirement under all operating conditions. If the power supply is unregulated, make sure voltage remains within these limits under all power line conditions. Ripple on the supply should not exceed 100 mV.

Loop Resistance – The maximum allowable loop resistance depends on the power supply voltage. Maximum loop voltage drop must not reduce the transmitter voltage below the 10 VDC minimum. Maximum loop resistance can be calculated with the following equation. V_{ps} is the power supply voltage.

$$R_{\max} = \frac{V_{ps} - 10.0}{20 \text{ mA}}$$

Some receivers, particularly loop powered indicators, may maintain a fixed loop voltage to power the device. This voltage drop must also be subtracted from the power supply voltage when calculating the voltage margin for the transmitter. The following equation takes this into account. V_{rec} is the receiver fixed voltage.

$$R_{\max} = \frac{V_{ps} - 10.0 - V_{rec}}{20 \text{ mA}}$$

0-10 V Output Models:

Verify appropriate supply voltage. The 0-10V output models require a DC supply of 15 to 35 V or an AC supply of 15-29 V for proper operation maximum. Both outputs may be loaded simultaneously with 5 mA.

MAINTENANCE

Upon final installation of the Series RHL Temperature/Humidity Transmitter and the companion receiver, no routine maintenance is required. A periodic check of the system calibration is recommended. The Series RHL is not field serviceable and should be returned if repair is needed (field repair should not be attempted and may void warranty). Be sure to include a brief description of the problem plus any relevant application notes. Contact customer service to receive a return goods authorization number before shipping.