

Frames for Bulk Flow Measurements

1. Frame for Rod Detector and Point Source

Radiometric Bulk Flow Measurements by BERTHOLD TECHNOLOGIES have been used for a long time in different branches of industry. These measurements can be installed in existing plants without difficult reconstruction of the conveyor like:

- belt conveyor
- screw conveyor
- chain conveyor

Today, by using advanced rod detectors, we offer interesting alternatives compared to previous measuring systems.

Benefit:

- easy installation on existing conveyors
- light frame without lead shielding

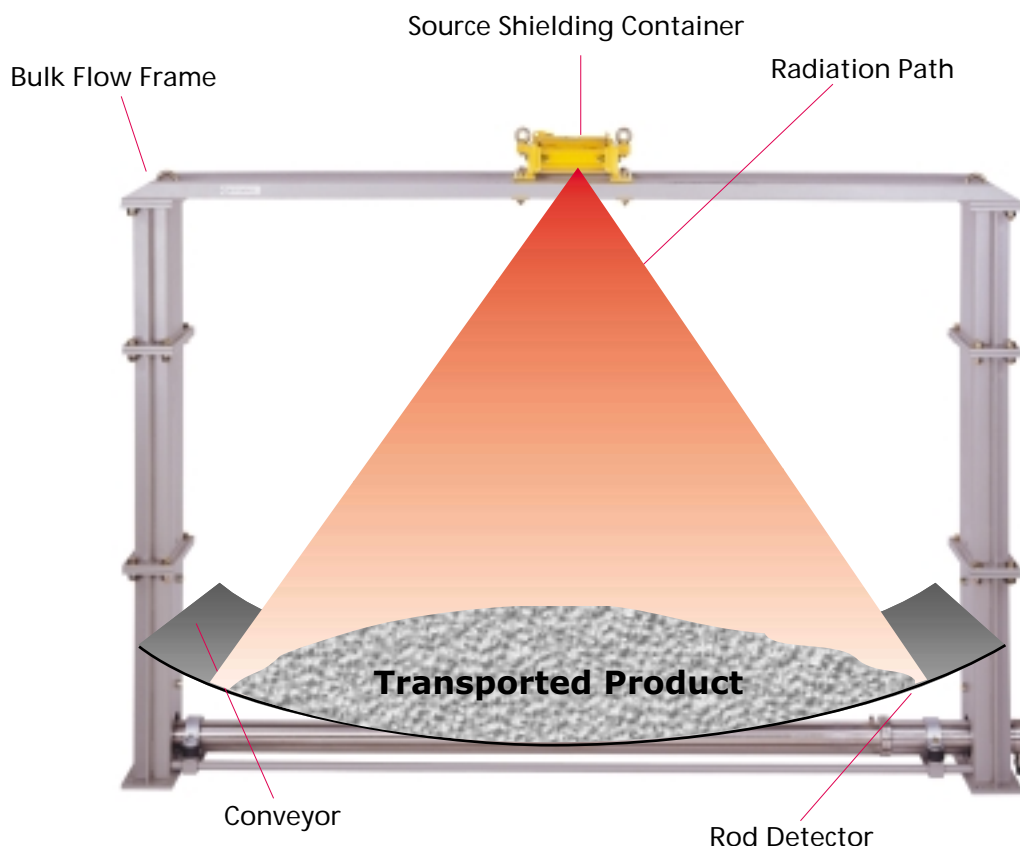

Measuring frames for rod detectors are available in following standard sizes (width x height in mm):

500 x 800 to 2800 x 2600.
For non-standard sizes, please contact us.

Frames for Bulk Flow Measurements

1.1 Parts

At low loading, Cesium point sources are effective. The point source shieldings are collimated to provide the most effective radiation protection. Some installations do not require a measuring frame,

which results in lower system and transport costs. Further cost savings are due to the high sensitivity of our rod detectors, which allow low activity sources and small shieldings to be used.

- Benefit:**
- light frame without lead shielding
 - small source shieldings

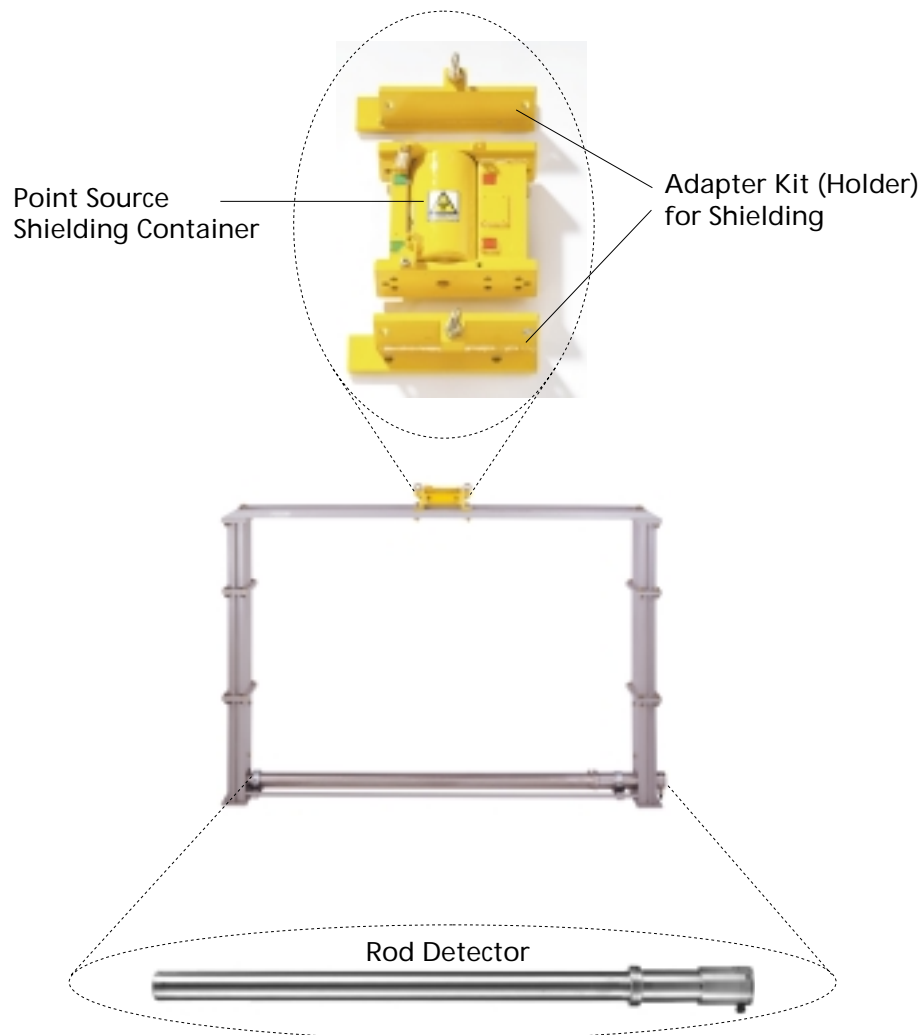

BERTHOLD TECHNOLOGIES rod detectors were originally designed for radiometric level measurements. By continuously improving sensitivity and stability,

our rod detectors now also meet the requirements of radiometric bulk flow measurements.

Frames for Bulk Flow Measurements

1.2 Rod Detector with Two Point Sources

Using 2 point sources can optimize measuring geometries on scraping conveyors fitted with rod detectors. This is because the point sources can be positioned anywhere along the length of the cross head

and this arrangement results in complete sensing of the material stream while using a very small measuring frame.

- Benefit:**
- full detection of the material stream
 - small and light frame without lead shielding

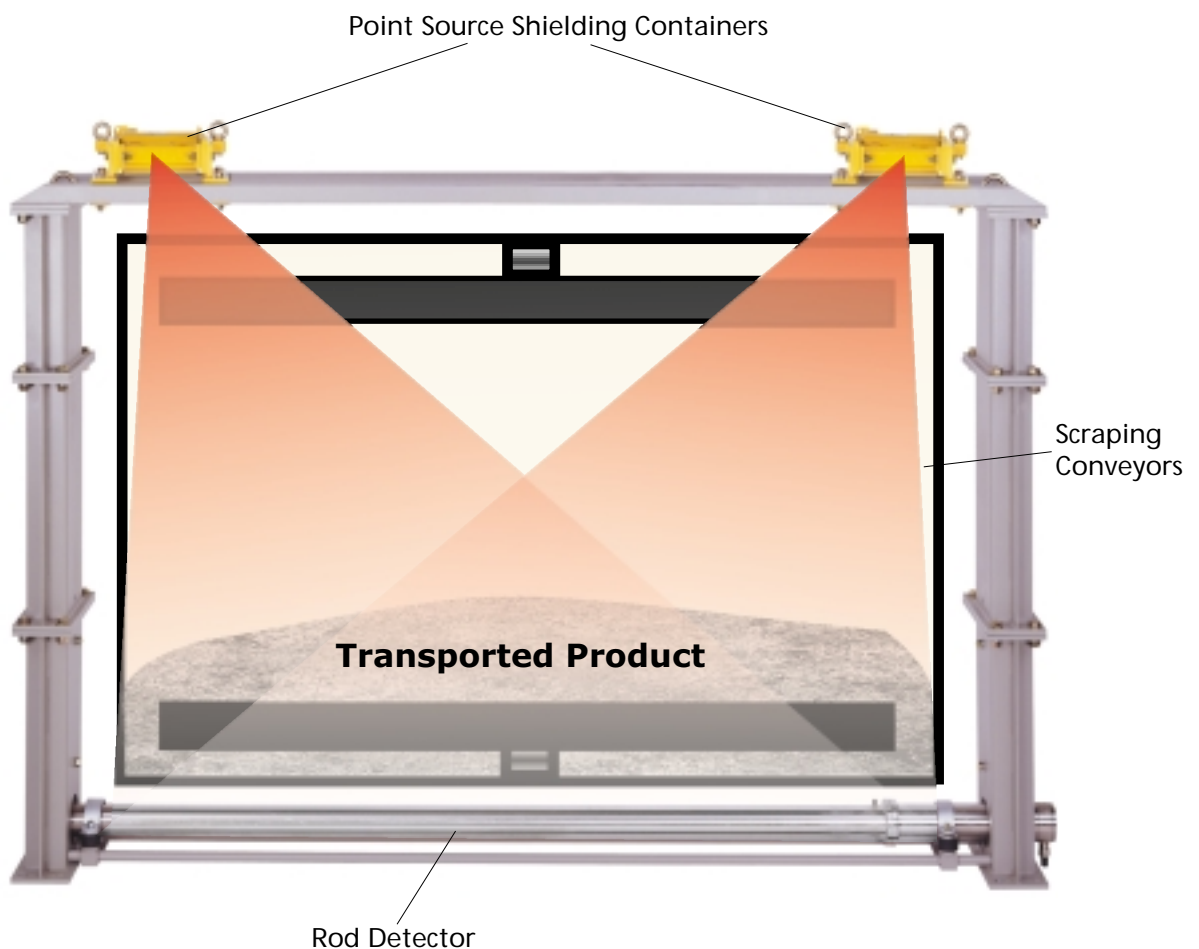

Because of the simple design of the measuring frame and the collimation of the point sources, on-site installation is simple and once the bar, detector

and shieldings are aligned correctly, they are permanently bolted in-place.

Frames for Bulk Flow Measurements

2. Rod Detector with Rod Source

When Cobalt-60 rod sources are required, their use with rod detectors results in very low activities. This combination provides perfect measurement geometries when used on a scraping conveyor. Due to the parallel alignment of rod source and

rod detector there is no influence from the surface shape of the conveyed material stream. An optional shield is available for our rod detectors. This will lower the background pulse rate and increase the accuracy.

- Benefit:**
- very low source activity
 - full detection of the material stream
 - small frame

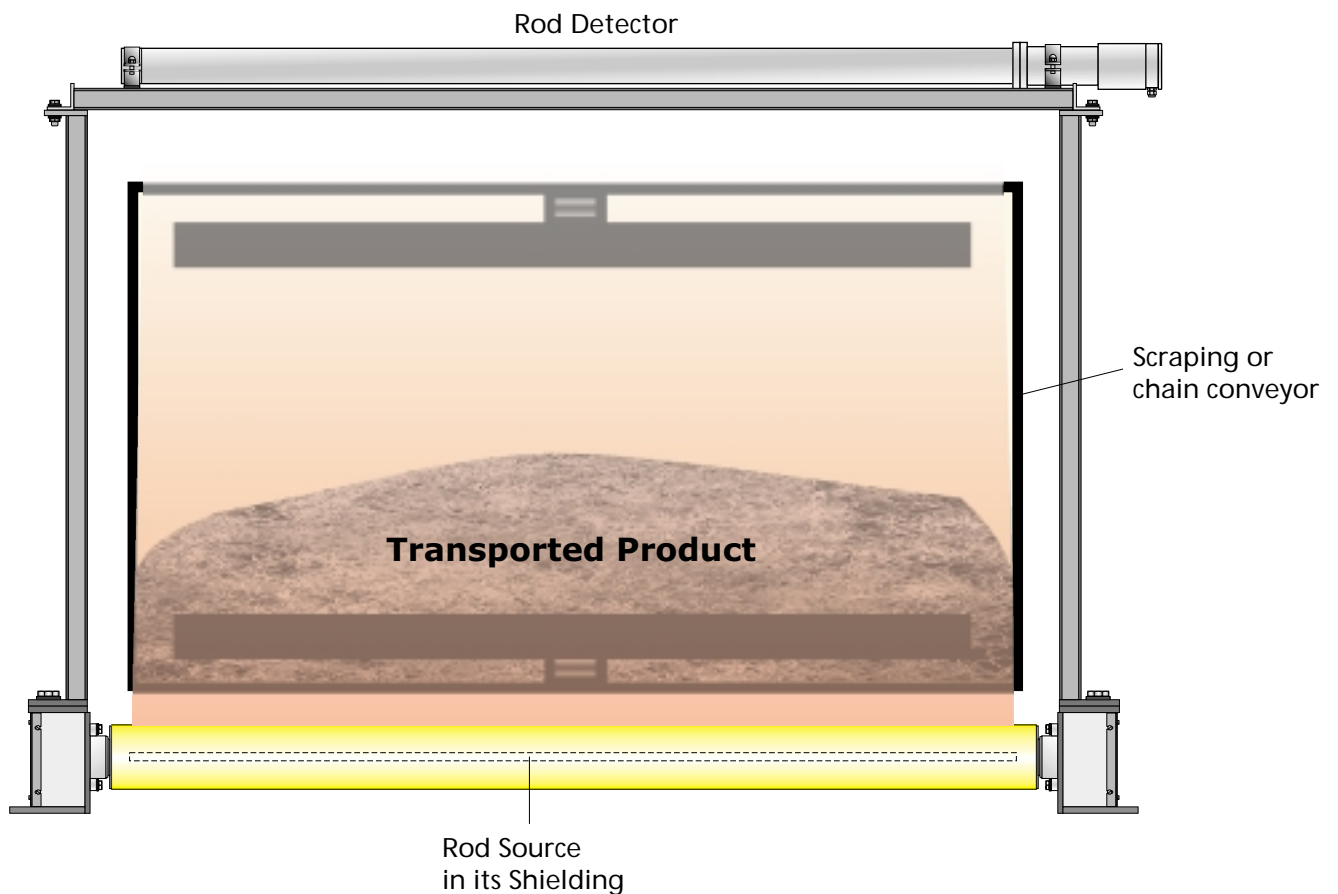

Berthold Technologies applications engineers or field service personnel are available to assist with the selection of the correct configuration for your

application. This can be initiated by filling out a questionnaire or by telephone conversation.

Frames for Bulk Flow Measurements

3. Point Detector with Rod Source

The activity profile of each Berthold Technologies Cobalt 60 rod source is tailored for the optimum fit to the geometry of the conveyor. This unique capability in combination with point detectors results in the ability to measure very low belt loading. Additional improvements over previous bulk-flow measurement systems include higher corrosion resistance, longer bearing life due to synthetic bear-

ings mounted in stainless steel holders and ease of detector installation by allowing the detector to be positioned anywhere along the length of the cross head. A larger shielding diameter is also specified to further improve radiation protection. For further information see leaflet LB 442 and "Technical Information LB 442".

