

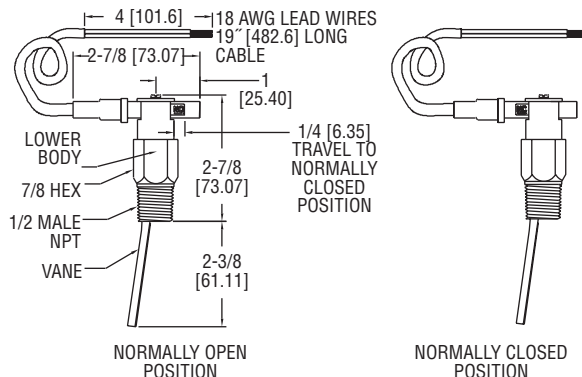

# Model V10 Flotect® Mini-Size Flow Switch

## Specifications – Installation and Operating Instructions



### INSTALLATION

1. Carefully unpack switch and remove any packing material from lower housing. Trim the vane at the appropriate mark for the size of pipe being used. See actuation/deactuation chart. **CAUTION:** Mechanical shock or vibration can cause permanent damage to the reed switch. Take care to avoid dropping the unit on hard surfaces or impacting the switch assembly.

2. Apply pipe thread sealant tape or pipe thread sealant to the 1/2" male NPT mounting threads and install switch in the system piping with the arrow on side pointing in the direction of flow.

3. Connect wiring in accordance with local electrical codes.

4. Inductive, capacitive and lamp loads can all create conditions harmful to the reed switch.

A) *Inductive loads* can be caused by electromagnetic relays, electromagnetic solenoids and electromagnetic counters, all with inductive components as the circuit load.

B) *Capacitive loads* can be caused by capacitors connected in series with or parallel to the reed switch. In a closed circuit the cable length (150 ft. or more) to the switch can introduce a capacitance.

C) *Lamp loads* can be caused by switching lamp filaments which have low cold resistance.

In addition to these causes, exceeding any of the maximum electrical ratings can lead to premature or immediate failure. This includes inrush and surge currents greater than the maximum switching current. Use caution when evaluating system loads and current. To accommodate these conditions, see diagrams on the reverse which depict possible solutions.

5. After installation, set the switch action to **NO** (normally open) or **NC** (normally closed). Normally closed contacts open and normally open contacts close when increasing flow actuates the reed switch. To change, loosen, but do not remove, the two screws on the top cap. Slide the reed switch assembly to expose the switch action selected. Tighten screws when adjustment is complete.

### MAINTENANCE/REPAIR

Upon final installation of the Model V10, no routine maintenance is required. The Model V10 is not field serviceable and should be returned if repair is needed. Field repair should not be attempted and may void warranty.

### WARRANTY/RETURN

Refer to "Terms and Conditions of Sales" in our catalog and on our website. Contact customer service to receive a Return Goods Authorization number before shipping the product back for repair. Be sure to include a brief description of the problem plus any additional application notes.

### SPECIFICATIONS

**Service:** Compatible gases or liquids.

#### Wetted Materials:

- Vane: 301 SS;
- Body: Brass or 303 SS;
- Pin and spring: 301 SS, 302 SS and 316 SS;
- Magnet: Ceramic 8.

**Temperature Limit:** 200°F (93°C).

**Pressure Limit:** Brass body: 1000 psig (69 bar); 303 SS body: 2000 psig (138 bar).

**Enclosure Rating:** Weatherproof, meets NEMA 4X (IP66).

**Switch Type:** SPST hermetically sealed reed switch. Field adjustable for normally open or normally closed.

**Electrical Rating:** 0.5 A @ 120 VAC; 1.5 A @ 24 VDC res.; 0.001 A @ 200 VDC res.

**Electrical Connections:** 18 AWG, 19" (483 mm) long, PVC jacket. Rated 221°F (105°C).

**Process Connection:** 1/2" male NPT standard. Contact factory for other options.

**Mounting Orientation:** Switch can be installed in any position but the actuation/deactuation flow rates are based on horizontal pipe runs and are nominal values.

**Set Point Adjustment:** Vane is trimmable.

**Weight:** 5.5 oz (0.16 kg).

**Agency Approvals:** CE, UL and CSA.

**Switch Enclosure:** Nylon.

Cold Water Flow Rates				Air Flow Rates			
Approximate actuation/deactuation				Approximate actuation/deactuation			
GPM upper, LPM lower				SCFM upper, LPM lower			
Pipe	Trim	N.O.	N.C.	Pipe	Trim	N.O.	N.C.
1/2"	L	2.6/2.3 9.8/8.7	2.6/2.5 9.8/9.5	1/2"	L	10.3/8.8 291.7/250	10.2/9.2 288/260
3/4"	J	3.1/2.7 11.7/10.2	3.1/2.8 11.7/10.6	3/4"	J	13/11.6 368.3/328	12.9/11.6 365/328
1"	H	4.8/4.5 18.2/17	4.8/4.4 18.2/16.7	1"	H	19.2/17.6 543.3/498	18.9/17.6 535/498
1-1/4"	E	6.2/5.6 23.5/21.2	6.1/5.6 23.1/21.2	1-1/4"	E	24.8/22.2 701.7/628	24.5/22.5 693/637
1-1/2"	C	8.2/7.7 31/29.1	8.2/7.7 31/29.1	1-1/2"	C	33.4/31.2 946.7/883	33/30.6 935/867
2"	Full	9.5/9.1 36/34.4	9.5/9 36/34.1	2"	Full	50.2/48.4 1422/1370	50.2/47.7 1422/1352

**REED SWITCH PROTECTION CIRCUIT INFORMATION BULLETIN**

**READ INFORMATION BELOW BEFORE INSTALLING YOUR NEW REED SWITCH CONTROL!**

Exceeding the current capacity of this Reed Switch control may cause **FAULTY OPERATION!** Be aware of the inductive and capacitive or lamp loads you may be placing on you Reed Switch Control. The circuits below outline possible solutions to preventing overloads due to inrush or surge currents exceeding maximum or when the switch current and product of the inductive back EMF exceed the switch's power rating. Also the circuit for prevention of overload when switching filament lamps (low "cold" resistance) is outlined below. Failure to follow these measures to protect Reed Switch Contacts may cause the contacts to weld together or result in premature wear.

**Possible Circuit Solutions Indicated by Dashed Lines**

**Inductive Loads**

*Possible causes –*

An electromagnetic relay, electromagnetic solenoid, electromagnetic counter with inductive component as circuit load.

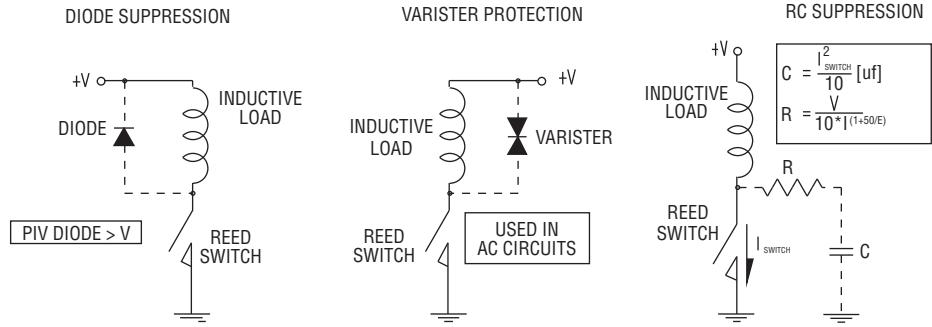

**Capacitive Loads**

*Possible causes –*

A capacitor connected in series or parallel with Reed Switch control. In a closed circuit, a cable length (usually greater than 50m [162.5 ft.]) used to connect reed switch may also introduce static capacitance.

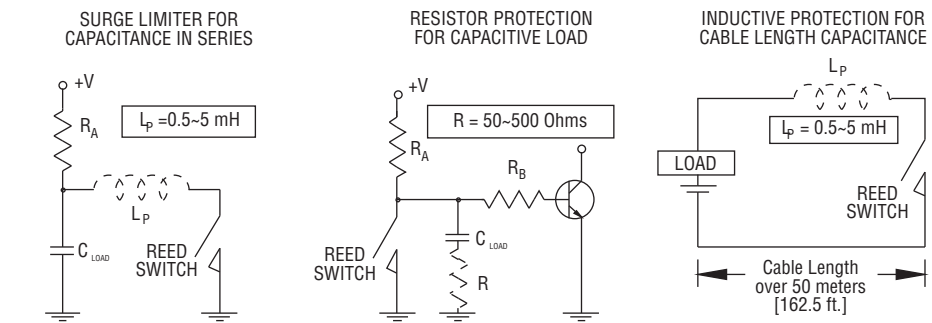

**Lamp Loads**

*Possible causes –*

A tungsten filament lamp load.



**Do not subject reed switch control to excessive shock and vibration, including:**

- Bending or placing force loads on reed switch housing
- Over-torquing fittings on reed switch housing
- Placing pull-out force on load wires