

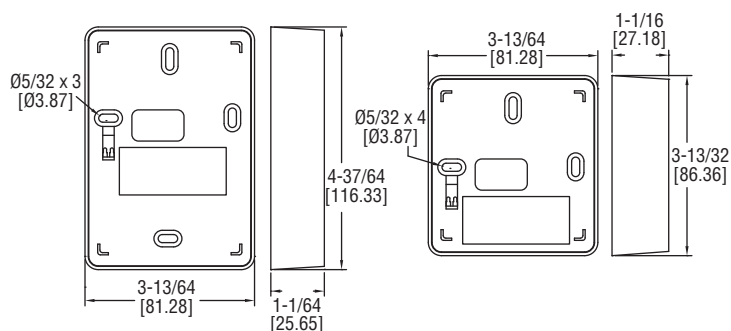

Series CDX Wall Mount Carbon Dioxide Transmitter

Specifications - Installation and Operating Instructions



The Series CDX Carbon Dioxide Transmitter is a low cost and high performing CO₂ sensor. On-Demand ventilation using CO₂ sensors prevents energy losses from over ventilation while maintaining indoor air quality. The potential for the greatest energy saving occurs in areas where occupancy varies over the duration of the day. The Series CDX Transmitters utilize a proprietary logic algorithm to eliminate the need for manual calibration in applications where the indoor CO₂ level drops to outside levels during unoccupied periods.

MOUNTING

Push the tabs on the bottom of the housing to remove the cover. Mount the back plate to the wall or junction box with the supplied screws and make the necessary wire connections. Attach the cover to the back plate by aligning the top clips and securing the bottom clips.

SELECTION OF VOLTAGE OUTPUT

Prior to wiring, verify that the voltage selection jumper is set to the desired output type. For voltage output selection, the output can be 0 to 5 VDC or 0 to 10 VDC. Voltage (see below).



0 to 10 V Jumper Selected (left), 0 to 5 V Jumper Selected (right).

SPECIFICATIONS

Range: 0 to 2000 PPM.

Accuracy: ±30 PPM or 3% of reading, whichever is higher. CO₂ accuracy statement excludes standard gas used for calibration that has an accuracy of 2% and there is a potential digital to analog error of up to 1%.

Temperature Dependence: 0.2% FS per °C (± 0.11% per °F).

Stability: < 2% of FS over life of sensor (15 years).

Pressure Dependence: .135% of reading per mm of Hg.

Response Time: 5 s.

Warm Up Time: < 2 min (operational), 10 min (max. accuracy).

Temperature Limits:

Operating: 32 to 122°F (0 to 50°C);

Storage: -40 to 158°F (-40 to 70°C).

Humidity Limits: 0 to 95% relative humidity, non-condensing.

Power Requirements: 18 to 30 VAC RMS, 50/60 Hz, or 18 to 42 VDC, polarity protected.

Power Consumption: .7 W @ nominal voltage of 24 VAC RMS.

Sensor: Non-dispersive infrared (NDIR) absorption.

Output: Analog, 0 to 5 V or 0 to 10 V jumper selectable (100 Ω output impedance), 4 to 20 mA (RL maximum 500 Ω).

Housing: Flammability classification UL94 5VA.

Weight: European Housing: 5.44 oz (154 g); North American Housing: 6.24 oz (177 g).

Agency Approvals: CE, RoHS.

WIRING CONFIGURATIONS

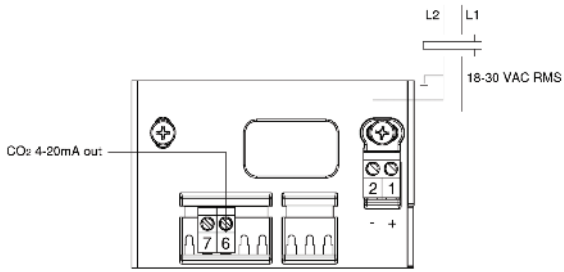

Figure 1: Current Wiring for 3-Wire System – AC Power

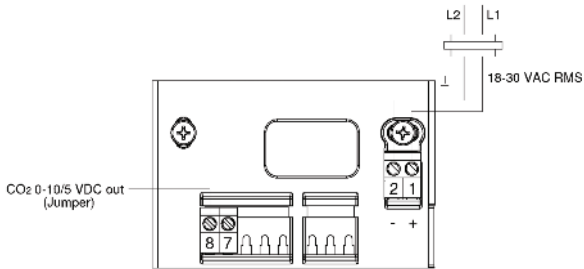

Figure 2: Voltage Wiring for 3-Wire System – AC Power

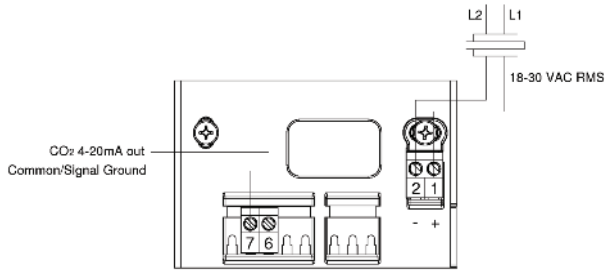

Figure 3: Current Wiring for 4-Wire System – AC Power

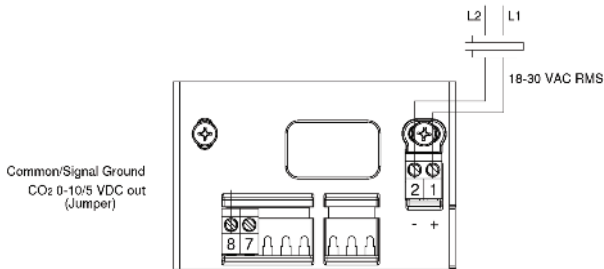

Figure 4: Voltage Wiring for 4-Wire System – AC Power

WARNING Before performing service or maintenance operations on the systems, turn OFF main power switches to the unit. Electric shock can cause personal injury. Please read and follow the wiring instructions precisely because improper wiring may cause permanent damage to the product.

The Series CDX has two terminal pins that are connected inside the sensor to a common/ground: pin #7 on the I/O terminal blocks and pin #2 on the power block. Do NOT connect positive 24 VAC power line to pin #2 of the terminal block.

CAUTION The Series CDX is either a 3-wire or 4-wire type configuration, powered by either AC or DC voltage. It is not a 2-wire or loop device. Wiring the units as 2-wire or loop-powered devices will irreparably damage the sensors and void the warranty.

POWER SUPPLY REQUIREMENTS

The sensor can be powered with either 18 to 30 VAC or 18 to 42 VDC, while the DC power is polarity protected. AC power must be at a frequency between 50 to 60 Hz.

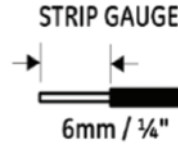

Recommended length of wire after being stripped of insulation for terminal pin (left).

CALIBRATION

The Series CDX is factory set with the proprietary logic function activated. The logic function allows the sensor to continuously re-calibrate itself when the indoor concentrations drop to levels similar to outside conditions when the building is unoccupied. The building must be unoccupied for a minimum of 4 hours or more for this self calibration to be effective. The logic allows the sensor to maintain its calibration over the life of the sensor.

ACCESSORY ENCLOSURES

When mounting these products inside the ductwork, seal the hole around the wires and leave the duct insulation in place to prevent condensation which may damage the sensor.

Model 1508 Duct Mount Enclosure

The CDX units can be installed inside a Model 1508 Duct Mount Enclosure.

Model 1552 Outside Air Measurement Enclosure

This NEMA-3R weatherproof enclosure includes thermostat and allows installation of the sensor in environments with temperatures down to -40°F (-40°C).

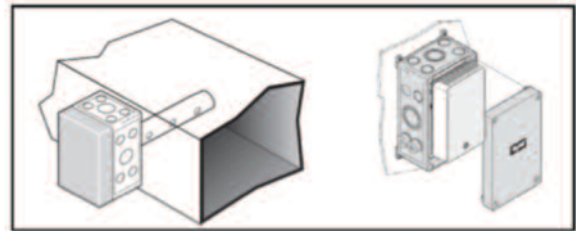

Duct Mount Enclosure (left), Outside Air Enclosure (right)

MAINTENANCE/REPAIR

Upon final installation of the Series CDX, no routine maintenance is required. The Series CDX is not field serviceable and should be returned if repair is needed. Field repair should not be attempted and may void warranty.

WARRANTY/RETURN

Refer to "Terms and Conditions of Sale" in our catalog and on our website. Contact customer service to receive a Return Goods Authorization number before shipping the product back for repair. Be sure to include a brief description of the problem plus any additional application notes.